

# Spiral A



## Removable bowl Spiral mixer

### Use

New removable-bowl spiral kneading machine for intensive use. Suitable for use by small craftsmen or industrial manufacturers, the new Spiral A is capable of kneading different types of dough in succession, while maintaining a real guarantee of quality at all times.

### Construction

- Reinforced rigidified steel structure
- Structure mounted on 6 feet for easy cleaning
- External structure coated with epoxy (food grade)
- Front surface of head and body coated with stainless steel protective layer
- Safety grille on bowl or sealed stainless steel safety lid for reduced dust emission
- Lower edge of stainless steel bowl specially shaped with "almond-shaped beading" to provide better coupling between the driving system and the bowl.
- Bowl strengthened by a welded flat strip.
- Stainless steel arm, bowl and dividing plate
- Easy fitting and removal of the bowl using the hydraulic head lifting mechanism.
- Bowl pre-connection device makes it easy to fit the machine on an uneven surface.
- Friction wheel transmission of movement to the bowl.
- Belt and pulley transmission.
- 2-speed spiral rotation
- Variable bowl rotation speed
- Reverse bowl rotation available in 1st gear
- Electronic control panel with large LCD display
- Memory facility handles and names 99 recipes
- Fault warning device.
- The bowl, with its new ergonomic grip, is perfectly adaptable to any hydraulic or screw lifting system, discharging on to a bench or into a Bongard dividing hopper.

### Reference Model with Stainless Steel grid

99301010	Spiral A 250 E**
99301020	Spiral A 300 E
99301030	Spiral A 360 E

### Model with Stainless Steel lid

99301040	Spiral A 250 E **
99301050	Spiral A 300 E
99301060	Spiral A 360 E

### Accessories

99301011	Extra bowl on trolley 250 **
99301021	Extra bowl on trolley 300
99301031	Extra bowl on trolley 360

### Options

Infra-red temperature probe
Ingredient containers (max 2 containers)
External structure completely in steel inox

Machine complies with  regulations



32, route de Wolfisheim - F-67810 Holtzheim  
Tél : 33 (0)3.88.78.00.23 - Fax : 33 (0)3.88.76.19.18  
www.bongard.fr - bongard@bongard.fr

## Spiral A Removable bowl spiral mixer

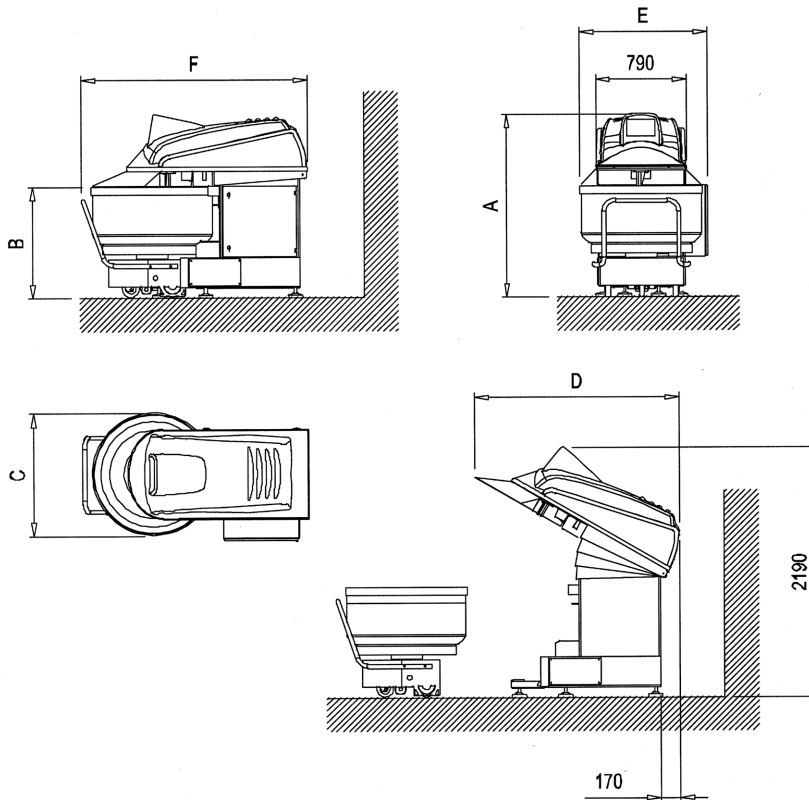

### Capacity

Model	Flour *	Dough *	Pouring *	Total
Spiral A 250 E	80 - 100 kg	120 - 160 kg	48 - 60 l	250 l
Spiral A 300 E	5 - 100 kg	8 - 160 kg	3 - 60 l	300 l
Spiral A 360 E	7 - 158 kg	11 - 253 kg	4 - 95 l	360 l

(\*) Indicative values

### Accessories

Model	Extra bowl on trolley			
	Flour *	Dough *	Pouring *	Total
Spiral A 250 E	80 - 100 kg	120 - 160 kg	48 - 60 l	250 l
Spiral A 300 E	5 - 100 kg	8 - 160 kg	3 - 60 l	300 l
Spiral A 360 E	7 - 158 kg	11 - 253 kg	4 - 95 l	360 l

Model	Total power	Net weight	Arm speed 50 Hz	Bowl speed 50 Hz	Arm speed 208 / 220 V 60 Hz	Bowl speed 208 / 220 V 60 Hz
Spiral A 250 E	10 kW	1205 kg	107 - 214	12,9	107 - 214	12,9
Spiral A 300 E	10 kW	1210 kg	107 - 214	12,9	107 - 214	12,9
Spiral A 360 E	13,6 kW	1265 kg	107 - 214	12,9	107 - 214	12,9
Bowl 250	-	325 kg	-	-	-	-
Bowl 300	-	295 kg	-	-	-	-
Bowl 360	-	325 kg	-	-	-	-

### Dimensions

Model	A Frame height	B Bowl loading height	C Internal bowl diameter	D Depth Raised head	E Width avec Electric Box	F Length head raised	Lift height
Spiral A 250 E	1604 mm	862 mm	900 mm	928 mm	976 mm	1860 mm	2190 mm
Spiral A 300 E	1604 mm	927 mm	900 mm	928 mm	976 mm	1860 mm	2190 mm
Spiral A 360 E	1604 mm	895 mm	1045 mm	1075 mm	976 mm	1980 mm	2190 mm
Bowl 250	-	862 mm	900 mm	-	-	-	-
Bowl 300	-	927 mm	900 mm	-	-	-	-
Bowl 360	-	895 mm	1045 mm	-	-	-	-